

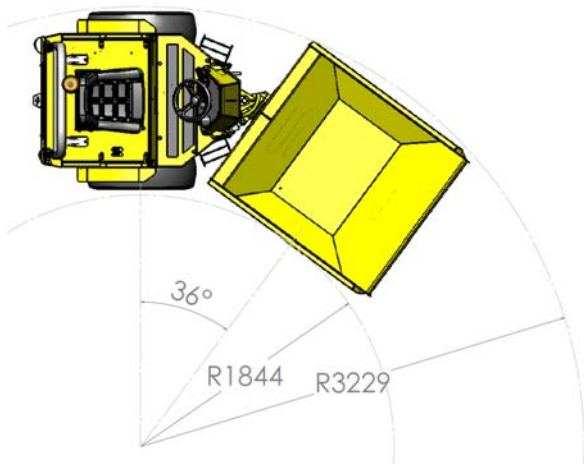

HT1.5

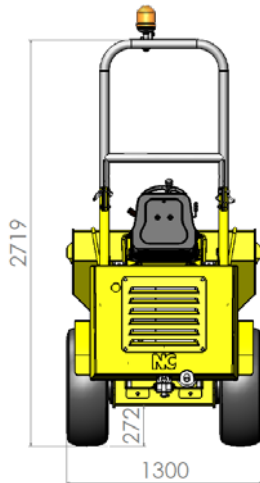
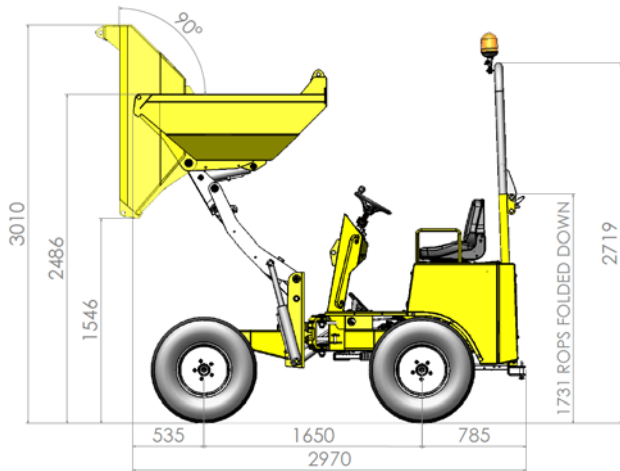
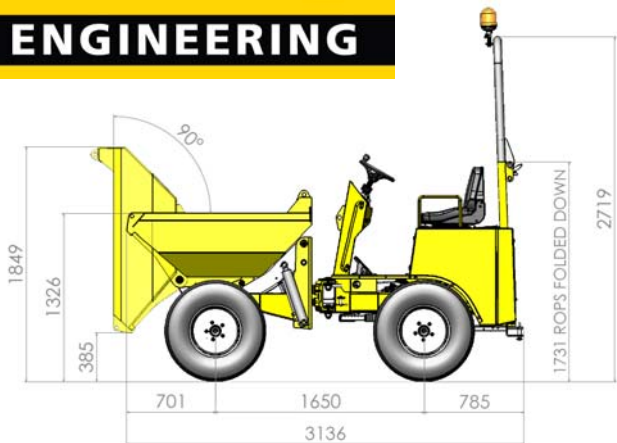

Capacity:

Max. safe load: 1500 kg
 Heaped: 805L
 Struck: 600L
 Water: 420L

Engine:

Kubota D1105 3 Cylinder, Water Cooled, Naturally Aspirated
 Displacement: 1.1 L
 Max. power: 17.5kW/23.4bhp @ 2800 rpm
 Max. torque: 72Nm @ 2000 rpm
 Emissions to: 97/68/EG

Transmission:

Hydrostatic automotive "Twin Lock" permanent 4 wheel drive
 Acceleration by foot pedal & braking from hydrostatic retardation

Drive characteristics:

Forward / Reverse 0-11 km/h (0-7 mph)
 Steering angle: +/- 36°
 Turning Circle: 6.45m
 Grade-ability: 50%
 Tyres: 10.0 / 75 / 15.3 (traction Profile)
 Steering: Priority load sensing hydrostatic centre pivot
 Working brakes: Hydrostatic retardation
 Park brake: Automatic in rear wheel motors

Noise Levels:

LWA 99dB(A)
 LPA 82dB(A)

Tank Capacities:

Fuel: 28L
 Hydraulic: 24L

Skip:

Hydraulically operated skip tipping to 90°
 Heavy duty fully welded skip with 5mm thick steel
 Reinforced around top for greater strength
 Operated by a twin levers for increased performance

Electrical:

Heavy duty H075 Battery: 12V, 550CCA, 59Ah
 Wiring harness in protective sleeving
 Reversing alarm

Hydraulics:

Automotive control hydrostatic pump
 8cc Gear pump
 Hydraulic test points fitted as standard
 Easy access return oil filter on top of tank

Seating & Controls:

Adjustable suspension seat accessible from both sides
 Clear access across dumper via galvanised steps
 Super bright warning lights on fully featured display instrument
 Steel constructed centre console for extra leg protection
 Column mounted directional control lever
 Anti-slip floor

Service Access:

Easy access for service maintenance
 Lockable hinged engine cover
 Battery mounted inside the engine bay



NC Engineering (Hamiltonsbawn) Ltd

2 Killyrudden Road, Hamiltonsbawn
 Richhill, Co Armagh
 Northern Ireland BT61 9SF

Tel: +44 (0) 28 3887 1970

Fax: +44 (0) 28 3887 0362

Email: sales@nc-engineering.com

Web: www.nc-engineering.com